

SMYTH DIGITAL SEWING LINE

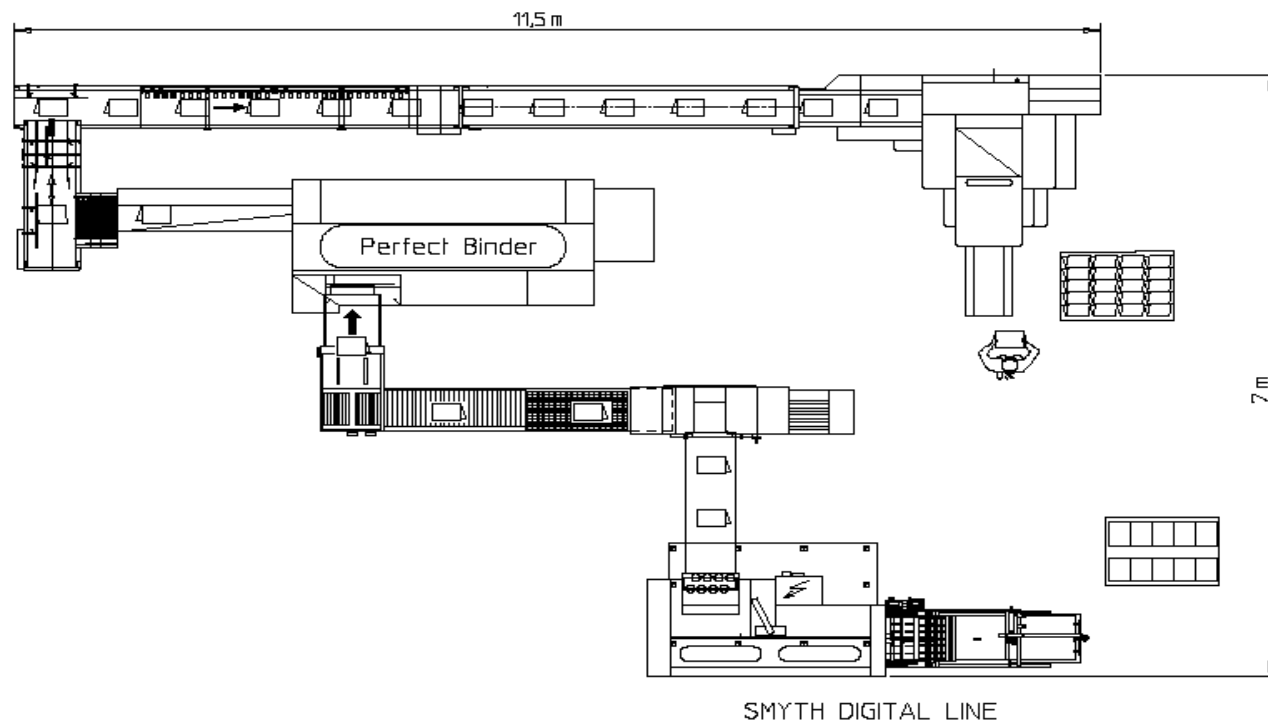

Note:

This layout is an example of inline production for a digitally printed book and is subject to change according to the customer's needs

TECHNICAL FEATURES

Size max.	Printed sheets : 500 x700 mm. Sewn signature: 390 x 300 mm.
Speed max.	Pile Feeder : 160 sheets/min. Sewer : 60 cycles/min.
Stitches number	8
Distance between the stitches	24 mm.
Tension	380V - 50 Hz
Power	6 Kw
Total weight	2700 Kg.
Air pressure	max. 6 bar
Air consumption	max 200 NI/min.



SMYTH

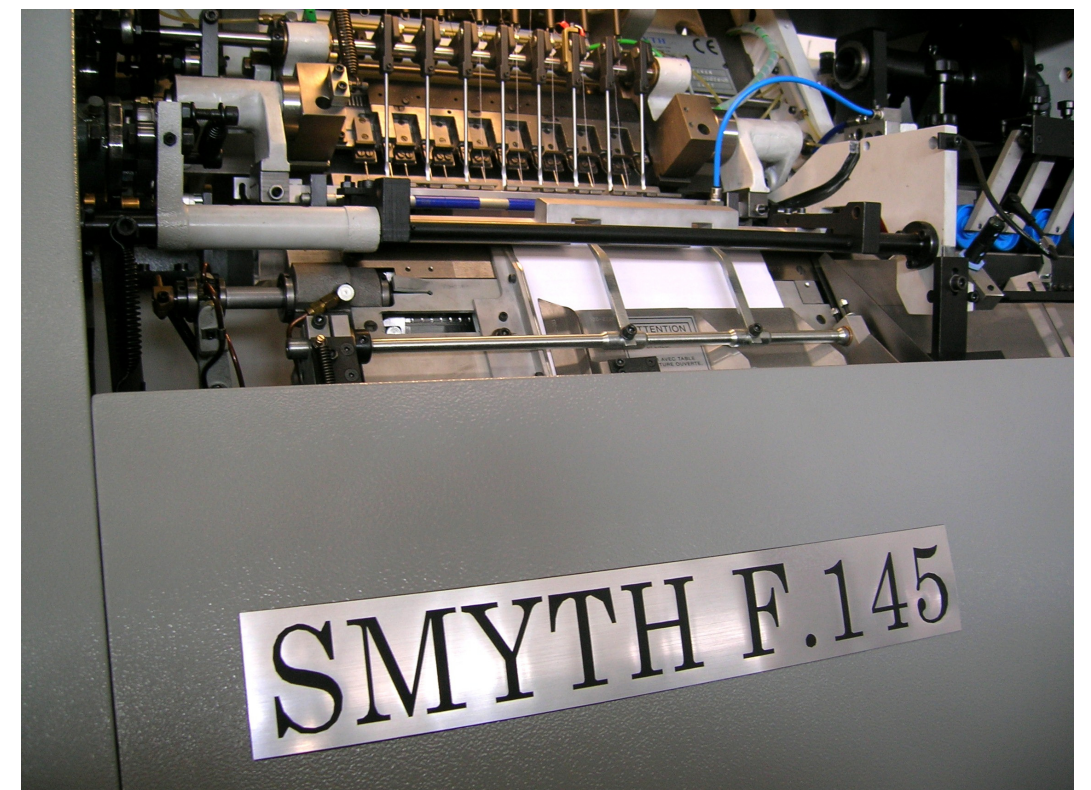

DIGITAL SEWING LINE

Smyth s.r.l. Regione Formica 10 S.S.31 Casale-Torino, 15030 Coniolo (AL) Italy
Tel.: 0142-56.33.66 fax: 0142-56.22.77 e-mail: freccia@smyth.it sito web: www.smyth.it



The Digital Sewing Line is an All New Integrated Production System for Digitally Printed Books comprising Folding and Thread Sewing. The new Folding Unit directly delivers Digital Sheets into the patented Smyth F145 Automatic Sewer increasing efficiency. Short Run Book Production also benefits from the advanced technical features which enable 4, 6 and 8 page signatures to be inserted into the new system offering great benefits to the entire digital / short run market.



The Folding unit benefits from two parallel fold possibilities to insert 4, 6 and 8 page sheets. The electronic knife is able to make one cross fold 4, 6 or 8 page sheets and transfer the inserted sheets onto the sewing machine saddle. The signatures are transferred via an Indexing System onto the mobile saddle to form the complete book.

The operator interface comprises a Touch Screen centrally positioned to enable all machine functioning parameters to be checked from both sides of the machine.

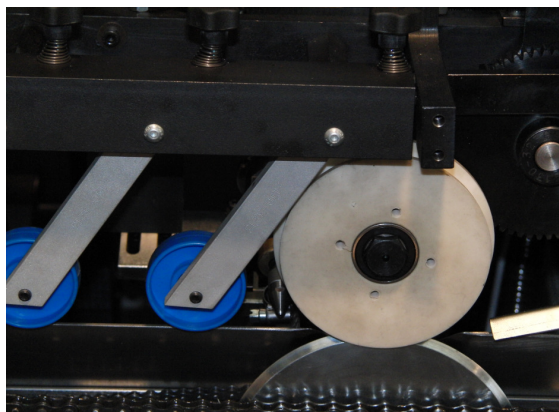

The reforming system for the back of the signatures comprises a lower and upper wheel guaranteeing the complete opening of the signature back for perfect centering of sewing stitches.

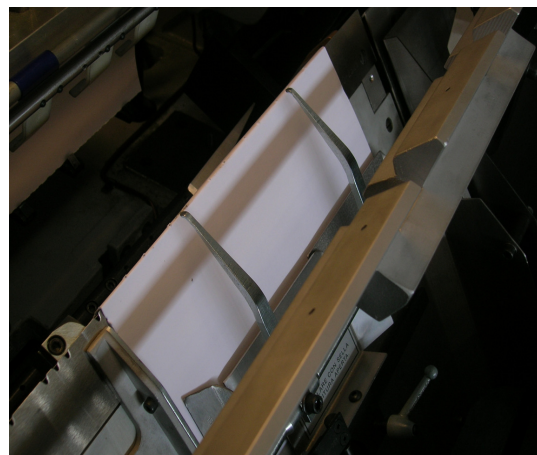

The mobile saddle is equipped with a precise signature locking system giving perfect positioning of the signature on the saddle and guarantees perfect centering of sewing stitches.

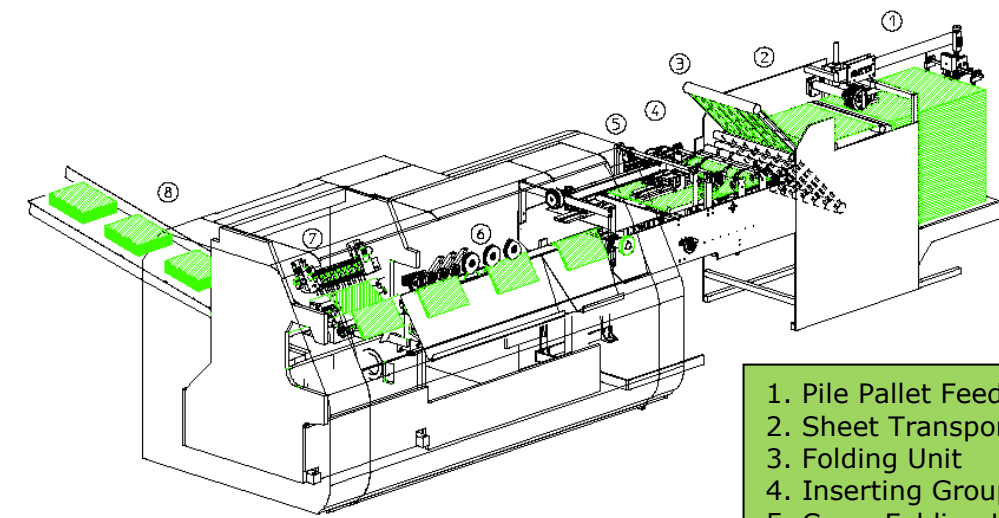
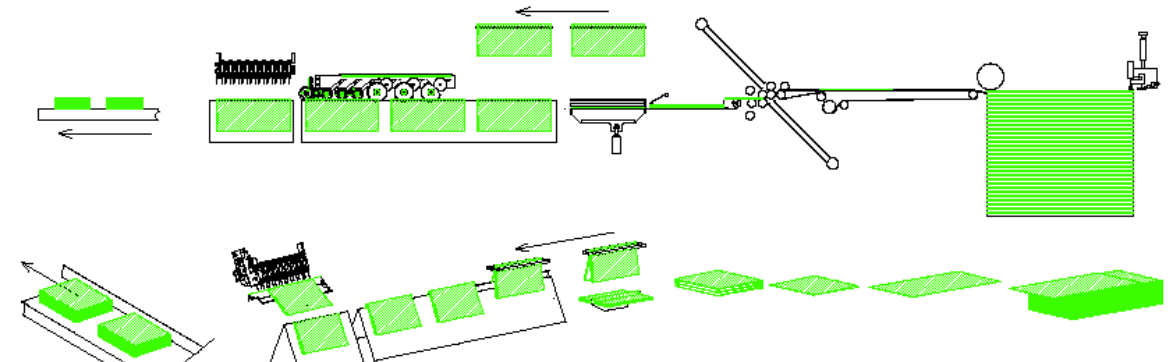

1. Pile Pallet Feeder
2. Sheet Transport
3. Folding Unit
4. Inserting Group
5. Cross Folding Unit
6. Reforming Wheels
7. Sewing Machine
8. Sewn Books Delivery

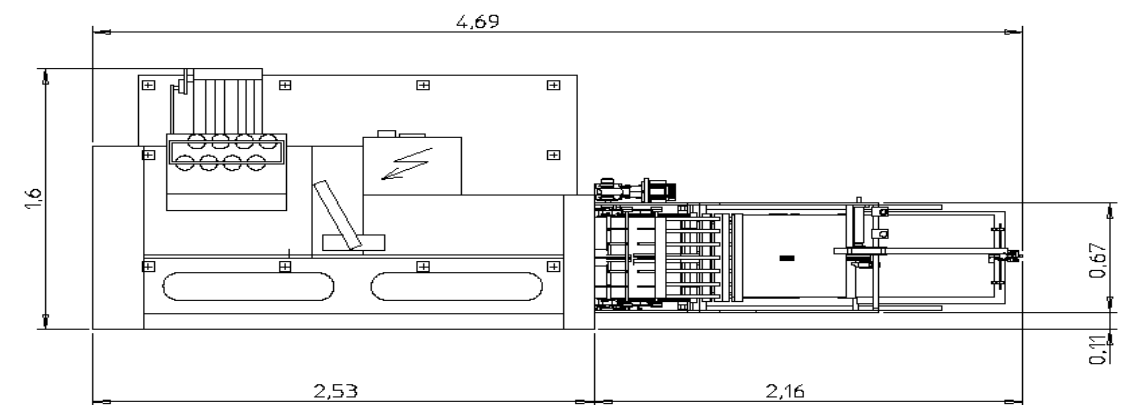

The compact design with the pile feeder (input) and sewn books (output) close together enable one man operation.